

C-400 RAM ASSEMBLY INSTRUCTIONS

For Air-Hydraulics, Inc. "C"- Series Presses with Model Numbers; C-400, C-400A, and Air-Hydraulics Ram Assembly Model Number: C4-RCA.

Instructions to replace seals and gaskets.

1. Once removed and disassembled, check inside wall of cylinder tube for excessive, rusting, pitting, scaring and deep linear groves running length of tube. The inside tube surface should be smooth. If not, cylinder tube needs to be replaced.
2. Check surface of ram or piston, where it is in contact with seals for excessive, rusting, pitting, scaring and deep linear groves running length of piston rod. If this condition exists, component should be replaced.
3. Lightly grease all sliding components, O-rings & seals, prior to assembly. This will aid in re-assembly.
4. It is important to orient "U"-seal properly. See below.
5. Be sure not to drag or to prevent seals from dragging over rough edges, sharp shoulders, or threads of ram or piston when reassembling unit. This may damage the seals and cause leaking.
6. There maybe gaskets or O-ring left over or not used. This kit services more than one model/Type.
7. It is important that the system be bled, once reassembled, to remove excess air in the closed hydraulics system. See Operator's manual for bleeding instructions. Manuals are available at www.airhydraulics.com.

When reassembling, do not let seals drag over rough, sharp edges or threads of piston rod or piston seals as this may damage the seals and cause leaking.

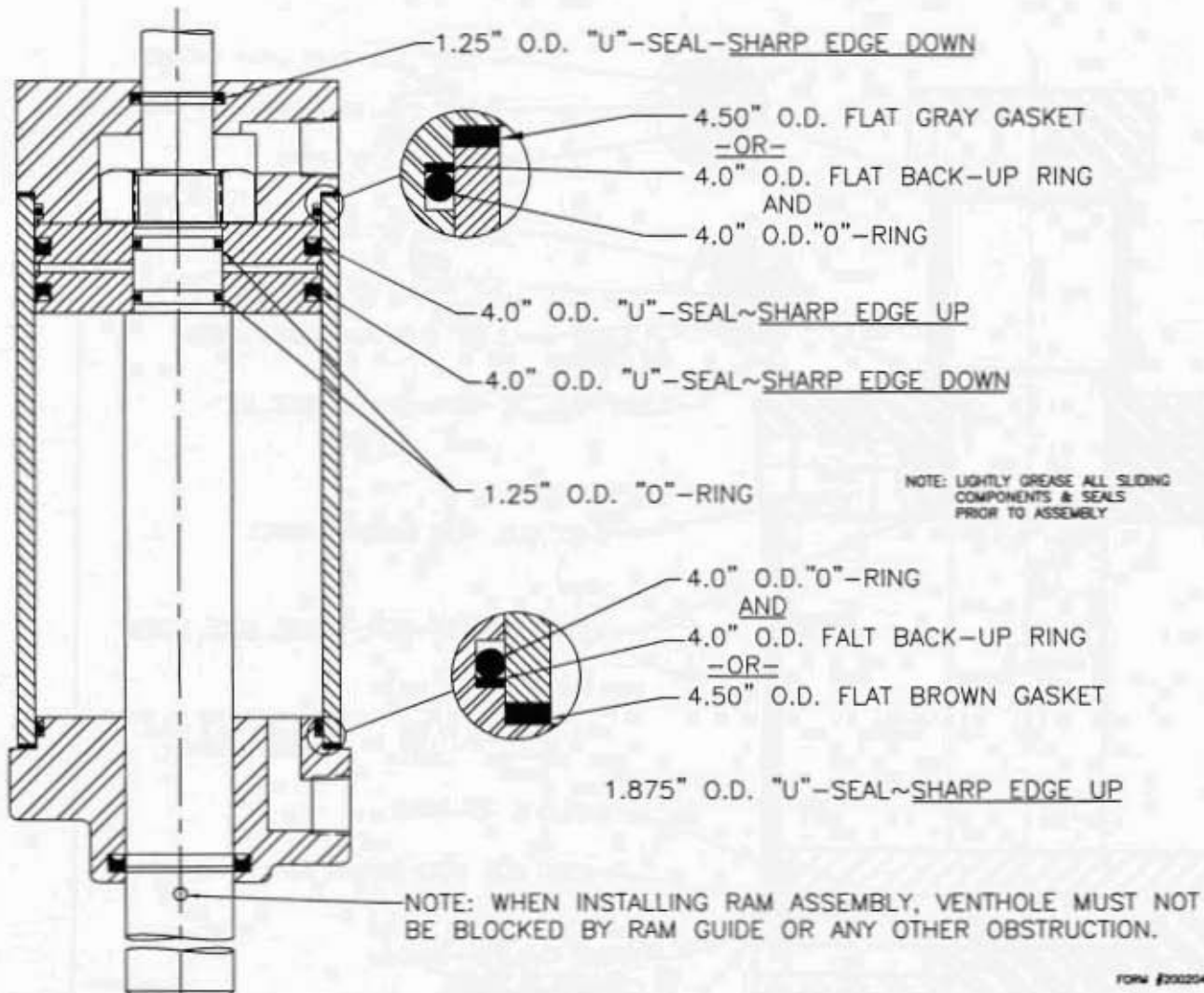

C-400 BOOSTER ASSEMBLY INSTRUCTIONS

For Air-Hydraulics, Inc. "C"- Series Presses with Model Numbers; C-400, C-400A, and Air-Hydraulics Boosters or Intensifiers with Model Numbers; C4-BCA.

Instructions to replace seals and gaskets.

1. Once removed and disassembled, check inside wall of cylinder tube for excessive, rusting, pitting, scaring and deep linear groves running length of tube. The inside tube surface should be smooth. If not, cylinder tube needs to be replaced.
2. Check surface of ram or piston, where it is in contact with seals for excessive, rusting, pitting, scaring and deep linear groves running length of piston rod. If this condition exists, component should be replaced.
3. Lightly grease all sliding components, O-rings & seals, prior to assembly. This will aid in re-assembly.
4. It is important to orient "U"-seal properly. See below.
5. Be sure not to drag or to prevent seals from dragging over rough edges, sharp shoulders, or threads of ram or piston when reassembling unit. This may damage the seals and cause leaking.
6. There maybe gaskets or O-ring left over or not used. This kit services more than one model/Type.
7. It is important that the system be bled, once reassembled, to remove excess air in the closed hydraulics system. See Operator's manual for bleeding instructions. Manuals are available at www.airhydraulics.com.

When reassembling, do not let seals drag over rough, sharp edges or threads of piston rod or piston seals as this may damage the seals and cause leaking.

