

# C-Series AIR-HYDRAULIC PRESS

Fluid Power Leveraging

**air-hydraulics**  
INCORPORATED

## THE COST EFFECTIVE AND ENERGY EFFICIENT ALTERNATIVE TO THE FULL HYDRAULIC PRESS

### OVERVIEW

The C-Series Air-Hydraulic Press is a more cost and energy efficient alternative to the Full Hydraulic Press Machine.

These C-Series Units come in four sizes ranging from 2.5 ton to 15 ton capacity. Standard features include a full length power stroke, 2.0" adjustable down-stop, and an anti-rotation ram guide. These heavy duty C-frame Units can be mounted on a floor stand or bench top and have an adjustable force and speed control.

### OPERATION

When the valve is energized, air enters the booster cylinder extending the booster ram. This transfers the oil into the ram cylinder, extending the cylinder rod down. Unlike other brands, hydraulic pressure is maintained throughout the entire stroke, not just a limited part of the stroke. When the valve is de-energized, the ram retracts to full home position.

### ADVANTAGES

- Fewer moving parts
- Less maintenance, less down time
- Less noise
- Full length power stroke
- Less heat
- Cost less than electric powered hydraulic presses



### SPECIFICATIONS

Description	2.5 Ton Press	5.5 Ton Press	10 Ton Press	15 Ton Press
Tons at 100 psi Air	2.5	5.5	10	15
Power Ratio (No. x air line psi = Approx. Force)	50	110	200	300
Max. Ram Stroke (adjustable 2" shorter)	5.1875"	6"	4"	6"
Cubic in. of Pressurized Air Per Full Stroke Cycle	577	1562	1865	4521
Air Cyl. Port Pipe Size - 4 Way Control Valve	.50"	.75"	.75"	1.0"
Return Force @ 100 psi	628	1080	1080	2003
<b>Booster Cylinder</b>				
Inside Diameter	6"	8"	8"	12"
Rod Diameter	2.125"	2.50"	1.875"	3.25"
Stroke	10.250"	15.625"	18.500"	20.187"
<b>Ram Cylinder</b>				
Inside Diameter	3"	4"	4"	5.75"
Top Rod Diameter	0.750"	1.000"	1.000"	1.250"
Bottom Rod Diameter	1.000"	1.500"	1.500"	2.750"
Net Weight	350 lbs.	500 lbs.	500 lbs.	800 lbs.

## C-SERIES PRESS DIMENSIONS

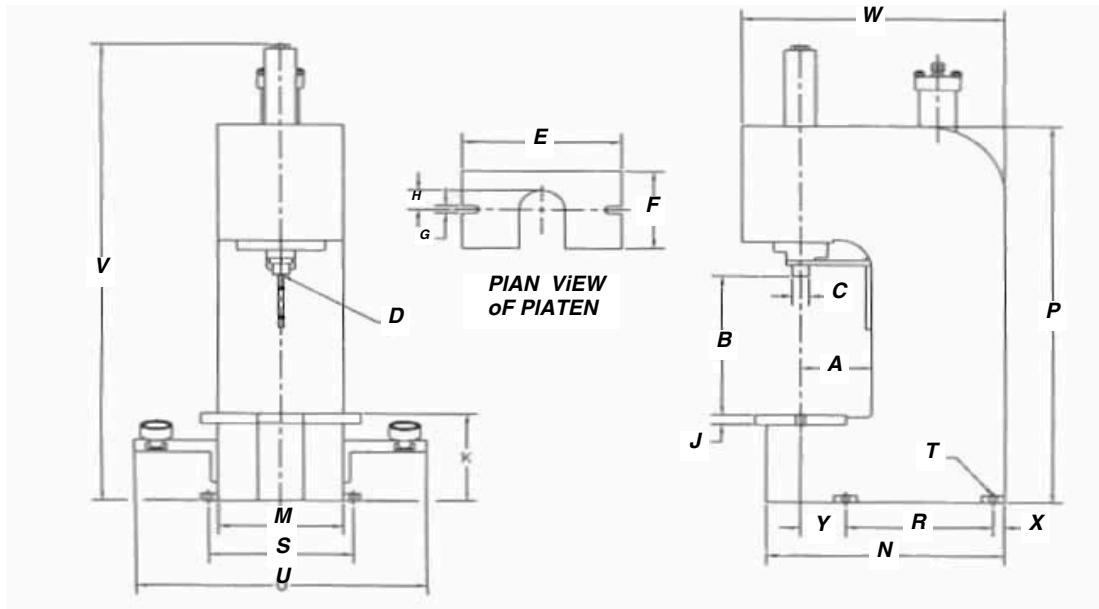

DIM KEY	DESCRIPTION	C-250	C-300	C-400	C-500
A	Throat Depth	6.25	6.25	6.25	8.25
B	Daylight	12.00	14.43	14.43	14.00
C	Ram Diameter	1.000	1.500	1.500	2.750
D	Ram Mounting	.625 -11 x	.625 -11 x	.625 -11 x	1.25-12 x
E	Platen Width	1.25 12.50	1.25 14.00	1.25 14.00	1.88 18.00
F	Platen Depth	6.00	8.00	8.00	10.00
G	Platen Slot	0.62 x 1.50	0.75 x 1.50	0.75 x 1.50	1.25 x .88
H	Platen Radius	2.00	2.00	2.00	2.25
J	Platen Thickness	1.00	1.00	1.00	1.25
K	Platen To Floor	7.12	9.00	9.00	9.00
M	Frame Width	9.50	11.00	11.00	15.25
N	Frame Depth	18.00	21.00	21.00	28.00
P	Frame Height	32.12	39.00	39.00	40.00
R	Mounting Hole Depth	10.00	13.00	13.00	16.00
S	Mounting Hole Width	11.25	12.75	12.75	17.00
T	Mounting Hole	0.53	0.62	0.62	0.65
U	Overall Width	23.75*	25.25*	25.25*	29.50*
V	Overall Height	39.50*	46.50*	48.00*	52.00*
W	Overall Depth	20.00*	23.12*	23.12*	29.75*
X	Back Foot Mounting	1.00	1.00	1.00	1.25
Y	Front Foot Mounting	5.00	4.00	4.00	6.75

\* Denotes Approximate Dimensions

**C-SERIES MODELS**

Our objective is to offer you a solution to your assembly and forming needs. If our standard features or available options do not meet your application requirements, please consult our factory to see about us offering an affordable solution to meet your design needs.

**STANDARD FEATURES**

- No Hydraulic Power Unit or Electric Motor Needed
- Full Length Hydraulic Controlled Power Stroke
- 2.0" Adjustable Downstop (Stroke Adjustment)
- Anti-Rotation Ram Guide
- Flow Control (Speed Control)
- Heavy Duty Steel Welded C-Frame Construction
- Platen Cut-Out for Fixture and Part Accessibility

**AVAILABLE OPTIONS**

- Matching Floor Stands
- Two-Hand Non-Tie Down Control Packages
- Pressure / Dwell / Distance Return Options
- Jog Control Circuit
- Fault Circuit Control Package (E-FI)
- Increased Stroke Lengths
- Press Frame Modifications
- Cylinders sold separately

**CUSTOM DESIGNED OPTIONS**

- Light Curtains & Guarding Packages
- PLC Control Options
- 4-Post and 2-Post Designs
- Load Cell & Distance Monitoring Packages
- Selectable Modes of Operation
- Control Systems Designed for Future Expansion
- Custom Tooling and Fixture Packages
- Emergency Stop Control Circuit
- 24vDC Control Circuit
- Linear Position Transducer
- Custom Control Packages

**ISO 9001 REGISTERED (WITH DESIGN)**

Air-Hydraulics is committed to delivering quality products on time to achieve customer satisfaction. Air-Hydraulics uses a process approach to achieve this policy in accordance with ISO 9001 and is committed to continually improve at this process.

**MODEL C-250**

[Bench Top with EDP-1 Controls >](#)

**2.5 TONS**

@100 psi of Factory Supplied Air

**5-3/16" Overall Stroke**

with 2.0" Stroke Adjustment

**12.00" Daylight Opening**

**6.25" Throat depth**

**MODEL C-300**

[Floor Model with EDP-1 Controls >](#)

**5.5 TONS**

@100 psi of Factory Supplied Air

**6.00" Overall Stroke**

with 2.0" Stroke Adjustment

**14.43" Daylight Opening**

**6.25" Throat depth**

**MODEL C-400**

[Floor Model with Light Curtains & Press Guarding >](#)

**10 TONS**

@100 psi of Factory Supplied Air

**4.00" Overall Stroke**

with 2.0" Stroke Adjustment

**14.43" Daylight Opening**

**6.25" Throat depth**

**MODEL C-500**

[Floor Model with EDP-1 Controls >](#)

**15 TONS**

@100 psi of Factory Supplied Air

**6.00" Overall Stroke**

with 2.0" Stroke Adjustment

**14.00" Daylight Opening**

**8.25" Throat depth**



## C-SERIES STANDARD CONTROL PACKAGES

**EDP** = Electric Logic  
(110v electricity required)

**DP** = Pneumatic Logic  
(No electricity required)

**EDP-1 or DP-1:** Basic two-hand non-tie down control package with single regulator

Operator initiates and maintains both actuators at the same time to advance the press stroke. Once the operator releases one or both actuators, the ram returns to home position.

**EDP-AS-1 or DP-AS-1:** Basic two-hand non-tie down control package with dual regulator (adjust retract pressure)

Operator initiates and maintains both actuators at the same time to advance the press stroke. Once the operator releases one or both actuators, the ram returns to home position.

**EDP-1-NP or DP-1-NP:** Two-hand non-tie down control package with jog control

Operator initiates and maintains both actuators at the same time to advance the press stroke. If the operator releases one of both actuators during the downward stroke, the ram stops downward motion. The operator can either proceed with the downward cycle by re-initiating the actuators until the auto ram return option is met (see auto ram return options), or the operator can manually retract the ram to home position by pressing the manual ram return button.

*(Note: includes P-TD or E-TD Pressure with Timer Return as the standard auto ram return option)*

**EDP-AS-2 or DP-AS-2:** Two-hand non-tie down control package with low force approach stroke and an adjustable hydraulic intensified boost stroke

Operation: Operator initiates and maintains both actuators at the same time to advance the press stroke under a low force approach stroke. Once the adjustable limit switch is met, the control system shifts into a hydraulic intensified boost/power stroke. Once the operator releases one or both actuators, the ram returns to home position

### Auto Ram Return Options:

(Add to the above standard control packages – excluding the DP-1-NP or EDP-1-NP)

E = Electric Logic / P= Pneumatic Logic

**E-TD or P-TD:** Pressure with Timer Return

Pressure sensor initiates an adjustable press dwell timer which returns the ram

**E-DR or P-DR:** Distance with Timer Return

Distance sensor initiates and adjustable press dwell timer which returns the ram

**E-PSRO or P-PSRO:** Pressure Only Return

Pressure sensor only initiates the return of the ram

**E-FI:** Fault Circuit (only available in electric logic)

Fault indicator with reset for short stroke notification (press stroke did not complete the normal cycle). Pressure sensor initiates an adjustable press dwell timer which returns the ram. Also, includes illuminated manual reset indicator

**E-FIRR:** Ram Capture (only available in electric logic)

Pressure initiated ram capture (muting); allowing the operator to remove their hands from the actuators and an adjustable press dwell timer returns the ram. Complete with illuminated ram capture indicator and manual retract button

### Other Available Options

(please consult factory)

- 24vDC Control Circuit • Programmable Logic Controller (PLC) • Emergency Stop Control Circuit • Light Curtains and Guarding • Rod End Load Cell
- Linear Position Transducer • Press Force and Distance Monitoring • Custom Designed Control Systems

**\*\*\*Note: all control packages are assembled complete with necessary F-R-L unit, air lock-out valve, flow control valve, directional valve and exhaust mufflers.**