

HI/LO CYLINDER (Y SERIES)

INSTALLATION, OPERATING &
MAINTENANCE MANUAL



Black & Webster Products Division

air-hydraulics
INCORPORATED

545 Hupp Avenue • Jackson, Michigan 49204

Ph: 517-787-9444 • Fx: 517-787-7585

www.airhydraulics.com • info@airhydraulics.com

Serial No. _____

TABLE OF CONTENTS

General Safety.....	3
Warranty.....	3
Machine Guarding.....	3
Functional Description.....	4
Installation Guidelines.....	5
Cylinder Installation.....	6
Control Circuit Installation.....	7
Control Systems.....	7
Sequence of Approach Stroke to Power Stroke.....	8
Filling Procedure.....	9
Venting.....	9
Maintenance.....	10
Preventative Maintenance	11
Trouble Shooting.....	12
Parts Description/Location.....	13
Alignment Couplers.....	14

General Safety

The cylinders are designed and built according to the state of the art utilizing CAD/CAM techniques, accepted industry standards, Quality Assurance systems and trained personnel. All cylinders are designed and manufactured to be operationally safe however; due to the nature of the product (i.e. pressing) there are areas of the product which cannot be protected at the factory. For this reason, good personal safety procedures and practices are required to protect the operator and maintenance personnel. Risks may arise if the cylinder is used or maintained by untrained personnel or in any way which is inconsistent with its intended use and/or purpose.

WARRANTY

Air-Hydraulics, Inc. warrants to the original user that all products of our manufacture will be free from defects in material and workmanship and will possess the characteristics represented in writing by Air-Hydraulics, Inc. Claim for breach of the above warranty must be made within a period of (1) year from date of delivery to the user. Upon satisfactory proof of claim, Air-Hydraulics, Inc. will make any necessary repairs or corrections, or, at our option, replace defective parts at the factory, transportation charges prepaid. Charges for correcting defects will not be allowed, nor can Air-Hydraulics, Inc. accept goods returned for credit unless we are notified in writing and the return or correction is authorized by Air-Hydraulics, Inc. in writing. **THE FOREGOING IS IN LIEU OF ALL OTHER WARRANTIES, EXPRESSED OR IMPLIED, INCLUDING ANY WARRANTIES THAT EXTEND BEYOND THE DESCRIPTION OF THE PRODUCT.** This paragraph sets forth the extent of the liability of Air-Hydraulics, Inc. for breach of any warranty in connection with the sale or use of our products. It is understood that Air-Hydraulics, Inc. will not be liable for consequential damages such as loss of profit, delays or expense, whether based on tort or contract.

MACHINE GUARDING

Machine guarding is the responsibility of the user. Provisions must be made to protect the operator and other employees from injury as a result of contact with the work in progress, moving parts, mechanical motions of the press, etc. Air-Hydraulics, Inc. cannot provide "standard" guarding for its presses due to the variety of tooling and applications used by press owners. However, Air-Hydraulics, Inc. will be happy to install guards and similar safety devices for operator protection. These safety devices must be produced at the request of and with design approval of the purchaser.

4.0 Functional Description

4.1 HPI Series

Note: During the Approach and Retract stroke, air must be directed to port "B2". Failure to do so may cause the high pressure rod to extend into the valve block therefore stopping the cylinder work rod.

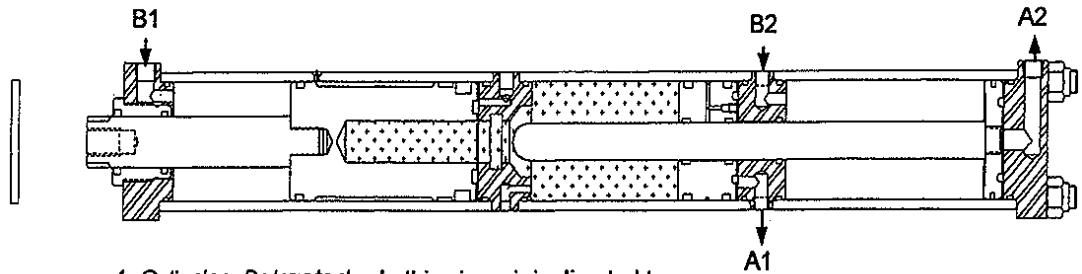

1. *Cylinder Retracted* - In this view air is directed to Ports B1, and B2 fully retracting the Reservoir, Working, and High Pressure Pistons.

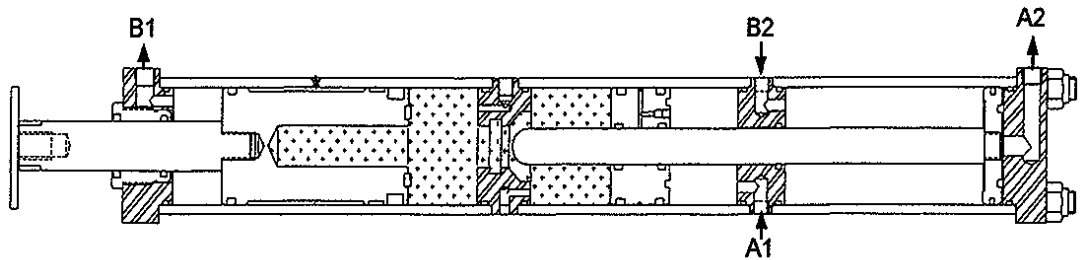

2. *Approach Stroke* - Air is directed to Port A1. The Reservoir piston advances, displacing the reservoir oil through the Valve Block to the back of the Working Piston, advancing the cylinder rod (at low force) until meeting resistance (work surface).

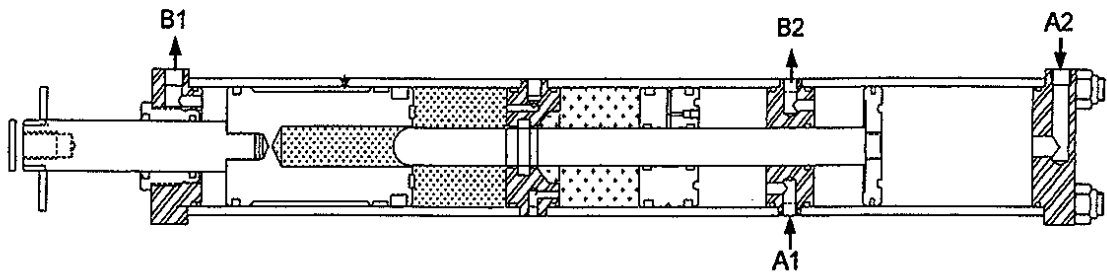

3. *Power Stroke* - Regulated air pressure is applied to Port A2. High Pressure Piston and Rod advance until contacting the Valve Block seal, isolating the reservoir oil from the oil contained in the working section. Continued movement intensifies and displaces the trapped oil developing the Power Stroke. Step 1 returns all three pistons and oil to the retracted position.

Installation Guidelines

Attach the cylinder to the mounting surface using SAE grade 8 bolts of the largest diameter possible, with a locking washer or thread locking material (LocTite). Torque the bolt or SHCS the appropriate specifications

Eliminate all possible side loading of the cylinder ram to tooling. Misalignment couplings or die-set couplings are highly recommended for all attachments (See page 14). Failure to do so could cause premature wear/failure of the cylinder wear-bands, seals and bearings and will void the manufacturer's warranty.

All Hi/Lo cylinders are provided with a high pressure (hydraulic gauge port) coupling and fill port coupling as standard. The ports are labeled with yellow tags. Allow room to access for future servicing and control options.

Hi/Lo cylinders can be installed in any position however, please be advised of the following. Horizontal mounting of the cylinder with a stroke length exceeding 4.00" must use the extended tie-rod option and make arrangements for a suitable attachment point at the cap end of the cylinder

Rod lock or a pilot operated check valve is highly recommended for all vertical, rod down applications. Failure to install either safety device may cause cylinder drifting during shutdown periods and potentially create a vacuum inside the cylinder.

7.0 Cylinder Installation

7.1 Attach the cylinder to the mounting surface with the integral head end mount. Use only grade 8 bolts.

7.2 Provide a way to reduce or eliminate side-loading of the cylinder rod. Failure to do so will cause excessive wear of the guide bearing, seals and wear strip.

 **Cylinders returned for repair with indications of side-loading will not be covered under warranty.**

7.3 All cylinders are provided with a high pressure gage coupling and reservoir fill coupling. Allow room to access for future options and cylinder service.

7.4 Punching and piercing applications must provide an external resistance to the cylinder rod and tooling prior to break-through. (see Fig. 7.4.1) Failure to do so may cause a vacuum inside the cylinder, adversely affecting performance.

7.5 Air directional control valves should be mounted within five, (5) feet of the cylinder. Use of suitable diameter tubing, (tube I.D. equal to the cylinder port size) is recommended.

7.6 Install an air lock-out valve on the main air supply line upstream to the directional control valves. If the air supply is to be shut off for an extended period of time and tooling weight exceeds 25% of the cylinder approach force, mechanically block tooling in the retracted position.

7.7 Do not exceed 100 PSI air pressure to the cylinder.

7.8 Use of clean filtered air, (40 micron minimum) is mandatory. Light lubrication of the supply air will extend cylinder service life.

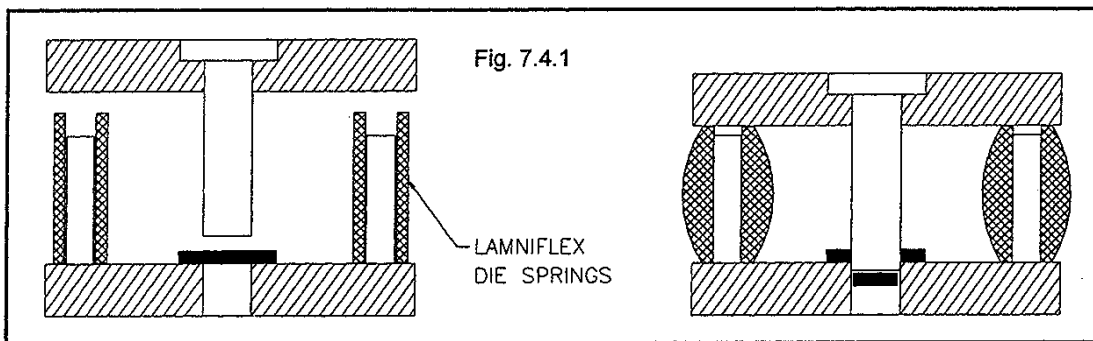

In many applications, the forward travel of the cylinder during high pressure is limited by the application itself, such as resistance welding, staking, etc. However, for punching and piercing applications the forward travel of the cylinder must be limited after punching through the material. If external resistance is not provided, the cylinder rod will continue to travel causing a potential vacuum in the high pressure/reservoir sections of the cylinder, adversely affecting performance. If a single point punch is used on the application, a single spring may be located around the punch which will also act as a stripper spring. We recommend use of LamniFlex Polyurethane Die Springs. Please contact AEC for additional information.

Control Circuit Installation

1. Use nylon tubing or rubber hose (Parker 801) is recommended for all pneumatic connections from the air directional control valves to the cylinder/reservoir/booster ports. Tubing I.D. should be at a minimum, equal to port size.
2. For best performance, all air directional control valves should be installed no further than 5 ft. from the cylinder
3. A 40 micron filtration system is mandatory. Air line lubrication is at the customer's option.
4. Install a lock-out/tag out safety valve up stream of the main air filter/regulator unit for shutdown and maintenance purposes.
5. Do not exceed 100 psi. air pressure to the cylinder
6. Please review the attached pneumatic control circuits. Mixing of 2-position, spring return and 3-position valve is not recommended.

Important Note: The output (cylinder) rod must return to full retract position at all times. Do not limit the upstroke of this cylinder.

NOTE

The Air-Hydraulics press has been carefully and accurately built to give long, trouble free service if properly installed and maintained. Carefully follow the instructions given in this manual. During maintenance procedures to this press, make sure no dirt or foreign material enters the cylinders or other working parts. If you have unusual problems regarding controls or tooling, notify Air-Hydraulics, Inc., Jackson, Michigan and our Engineering Department will be glad to assist.

Control Systems

Hi/Lo Cylinder control circuits are similar to two typical air cylinders, with one cylinder extending before the other, and both retracting at the same time. Each cylinder requires (2) pneumatic directional control valves for operation. Pneumatic directional control valves can either be mechanical, solenoid, or remote air piloted. Valve size must be of suitable flow to permit proper cylinder function.

Pneumatic flow control valves may be customer installed, (metered out) at cylinder ports B1 and B2 to control the speed of the cylinder and speed of the power stroke

Ensure the main air supply is dry, clean (40 micron), and if possible lightly lubricated

Unique to the Hi/Lo cylinder design is the ability to regulate the Approach Stroke force independently for the Power Stroke Force though the use of separate air regulators.

Stacking regulators installed on the valve manifold are recommended for best performance.

All Air-Hydraulics Hi/Lo cylinders require a minimum of two (2) 4-way pneumatic directional control valves, a filter, regulator, lubricator unit, and a plant air supply for proper operation. Sequencing into high pressure can be accomplished using a time delay (electrical or pneumatic), a customer supplied proximity switch, or an end of stroke threshold sensor (PT or ELT series sensor). A unique feature of all Air-Hydraulics Hi/Lo cylinders is the ability to provide the power stroke anywhere within the total stroke of the cylinder. For this reason, we recommend the use of the PT or ELT series sensors to indicate when the work rod (and therefore tooling) has contacted the work surface. For best cylinder performance locate the directional control valves within five (5) feet the cylinder. Use nylon tubing equal to the respective port diameter for all air line connections from the directional control valves to the cylinder. A pneumatic flow control valve (meter out) may be installed at port "B1" and/or port "A1" to control cylinder approach and retract speed. Please refer to Installation Guidelines for additional information.

Sequence of Approach Stroke to Power Stroke

All Hi/Lo cylinders may be sequenced into the Power Stroke anywhere within the total stroke of the cylinder. Sequencing into the Power Stroke is customer defined. Recommended suggestions are: Time Delay, External Proximity Switch, or Threshold Sensor.

***Threshold sensors are installed directly into the cylinder B1 port which detects the exhausting air from the B1 port. Once the air has exhausted to 6 psi., indicating the cylinder rod and customer's tooling have made contact with the work surface.

Refilling Cylinders

All Hi/Lo cylinders are pre-filled and tested at the factory. The internal oil reservoir contains sufficient excess oil, (30%) that, with normal operation will operate millions of trouble free cycles.

All cylinders are supplied with a reservoir fill coupling identified as "F" on the cylinder. The fill coupling is protected by a black rubber dust cap. Cylinders are also equipped with a low oil level indicator pin, which will extend outward approximately 3/16" when the cylinder requires refilling. To refill the cylinder, please use only the Hi/Lo fill unit with an ISO 32 hydraulic oil.

Filling Procedures

1. Fill the oil fill gun/unit with ISO 32 oil or equivalent
2. Retract the cylinder rod.
3. Depress the inner ring on the fill unit coupling (opening coupling), and depress the fill unit handle until all air has been vented from the fill unit tubing. Close the coupling
4. Remove the black rubber dust cover from the cylinder fill coupling. Connect fill unit to the cylinder
5. Repeatedly depress the fill unit handle until the unit handle becomes difficult to depress, cylinder is full.
6. Disconnect the fill unit from the cylinder. Replace the rubber dust cover. Push in the indicator pin. Procedure is complete

Venting

The Hi/Lo cylinders utilize a patented, total air/oil separation system which under normal operating conditions eliminates the possibility of air entering into the working and reservoir sections of the cylinder. Improper installation of oil pressure monitoring devices, and/or removal of either gauge or fill couplings will permit air to enter both oil sections of the cylinder. Air entrained in the oil will adversely affect cylinder performance.

1. Remove the fill line and coupling from the fill unit. Retract the cylinder rod and block up in the retract position
2. Remove the black rubber dust cover from the cylinder fill coupling. Connect the fill coupling to the cylinder. Place the opposite end of the fill line into a container of suitable size.
3. Depress and hold the manual override on the fast approach directional control valve until all the oil and air have been vented from the cylinder. Disconnect the fill coupling. Release the manual override.
4. Re-attach the fill unit coupling and line to the fill unit. Refill cylinder with oil (see fill procedure).

Maintenance

Due to the simplicity of this Air-Hydraulics, Inc. hi-lo press the only maintenance requirements for the continued operation of this press are as listed below.

Weekly checks:

1. Check oil level in air line lubricator. Check that the lubricator is working properly, i.e. dropping oil at the specified interval. This interval changes depending on the application, cleanliness of the air supply etc. a good starting point would be one drop per about every 12 press cycles. If however this causes oil to leak out of the mufflers, set for one drop every 18 to 20 cycles.
2. Check oil level in the main cylinder. This is done by looking at the oil level indicator at the back of the machine. If the plunger is pushed out this indicates a low oil level exists. Or look into the sight glass at the front of the machine, the piston should be visible in this window. If the piston is visible then the machine is o.k. to operate.
3. Check for air leaks in entire system.
4. Check for proper operation of the non-tie down system. Make sure that both palm buttons have to be actuated in order for the press to operate.

Yearly checks or those to be done through a Preventative Maintenance schedule.

1. Check oil level in air line lubricator. Check that the lubricator is working properly, i.e. dropping oil at the specified interval. This interval changes depending on the application, cleanliness of the air supply etc. a good starting point would be one drop per about every 12 press cycles. If however this causes oil to leak out of the mufflers, set for one drop every 18 to 20 cycles.
2. Check oil level in the main cylinder. This is done by looking at the oil level indicator at the back of the machine. If the plunger is pushed out this indicates a low oil level exists. Or look into the sight glass at the front of the machine, the piston should be visible in this window. If the piston is visible then the machine is o.k. to operate.
3. Check for air leaks in entire system.
4. Check for proper operation of the non-tie down system. Make sure that both palm buttons have to be actuated in order for the press to operate.
5. Change the in line air filter cartridge. This will need to be done more often if it gets dirty. This will be indicated by a brownish color in the filter cartridge.
6. Check that all regulators are functioning properly and are able to change the pressure when they are adjusted.
7. Remove and clean the “socket only” of the threshold sensor.
8. Check that the flow control regulates the speed of the ram both in approach and retract.
9. Check for proper operation of the power valves.

Air-Hydraulics Hi/Lo Presses

Model's AH5(x), AH10(x), AH15(x), AH20(x), AH30(x) and AH50(x)

Preventative Maintenance

1. Before any preventative maintenance is performed, turn off air supply to press and block up ram, following OSHA and local Lock out/Tag out procedures.
2. Keep the oiler/lubricator filled with Mobil DTE grade 24 or equivalent. Lubricator is adjusted at the factory, but it should be reviewed monthly. The larger the cylinder area, the more lubrication required. Use the following chart for a general rule of thumb.

Model No.	Cycles per drop
AH4(x)	4
AH9(x)	4
AH14(x)	4
AH20(x)	4
AH30(x)	5
AH50(x)	5

If the press ram is chattering, then increase the lubricator. If you are getting too much oil out of the exhaust air muffler, then decrease the lubricator.

3. Review and inspect air filter, it should be removed and replaced once filter element turns a tan or brownish color.
4. Check oil indicator, a round block located on the side of the cylinder. If brass pin pops out; cylinder is low on oil and needs to be refilled using an Air-Hydraulics, Inc. Oil fill Kit design specifically for this cylinder.
5. Check all safety devices DAILY for proper operation. If they are not functioning properly, DO NOT USE PRESS!

Trouble Shooting

12.0 Problems, Causes, Solutions

12.1 Cylinder Rod Doesn't Extend

Problem	Cause	Solution
Cylinder rod doesn't extend	<ul style="list-style-type: none"> -Compressed air supply insufficient -Directional control valves not shifting -Sideloading of the cylinder rod, (misalignment of the rod and tooling) -Air is not applied to the B2 cylinder port during the approach or retract stroke 	<ul style="list-style-type: none"> Increase air pressure Repair/replace valve Repair/install alignment coupling Repair control circuit

12.2 Cylinder Rod Doesn't Retract

Problem	Cause	Solution
Cylinder rod doesn't retract	<ul style="list-style-type: none"> -Compressed air supply insufficient -Directional control valves not shifting -Sideloading of the cylinder rod, (misalignment of the rod and tooling) -Air is not applied to the B2 cylinder port during the approach or retract stroke 	<ul style="list-style-type: none"> Increase air pressure Repair/replace valve Repair/install alignment coupling Repair control circuit

12.3 Cylinder Will Not Develop Power Stroke

Problem	Cause	Solution
Cylinder will not develop power stroke	<ul style="list-style-type: none"> -Compressed air supply insufficient -Directional control valves not shifting -reservoir oil is low -insufficient power stroke for application -air has been allowed into the oil sections of the cylinder 	<ul style="list-style-type: none"> Increase air pressure Repair/replace valve Refill reservoir Vent and/or refill cylinder

Replacement Parts Description

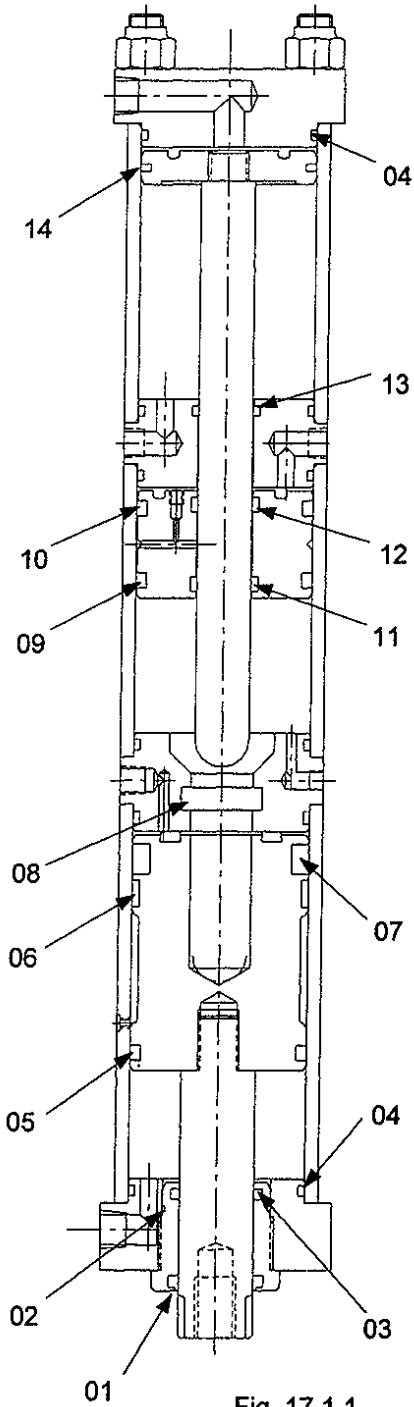

Fig. 17.1.1

No.	Qty.	Description
01	1	Rod Wiper
02	1	Bearing O-Ring
03	1	Bearing U-Cup
04	6	Tube O-Ring
05	1	Work Piston U-Cup (Pneu.)
06	1	Piston Bearing
07	1	Work Piston U-Cup (Hyd.)
08	1	Valve Block U-Cup
09	1	Reservoir Piston O.D. U-Cup
10	1	Reservoir Piston O.D. U-Cup
11	1	Reservoir Piston I.D. U-Cup
12	1	Reservoir Piston I.D. U-Cup
13	1	Seperator Block O-Ring
14	1	Teflon Wear Ring
	1	High Pressure Piston O-Ring

AIR-HYDRAULICS ALIGNMENT COUPLER SETS

MACHINE	MALE ADAPTER		PERM. RING	QUICK RING		D	E	F	G	H	J
	TONS	A		B	C						
12A, 28A, 50A	1-2.5	CA1-1	1/2-20	2.38	1.00	3.25	0.75	5/16 SHCS	.528	1.133	.884
C280	2.5	CA1-2	5/8-11	2.38	1.00	3.25	0.75	5/16 SHCS	.528	1.133	.884
AH-5	5	CA1-3	3/4-16	2.38	1.00	3.25	0.75	5/16 SHCS	.528	1.133	.884
C300, CA00	5-10	CA3-4	5/8-11	8.00	1.13	4.50	1.13	3/8 SHCS	.788	1.701	1.328
C500	15	CA3-5	1 1/4-12	9.00	1.13	4.50	1.13	3/8 SHCS	.788	1.701	1.328
AH-10, AH15, AH20	10-30	CA3-6	1 1/2-12	9.00	1.13	4.50	1.13	3/8 SHCS	.788	1.701	1.328
AH-30	30	CA3-7	1 7/8-12	9.00	1.13	4.50	1.13	3/8 SHCS	.788	1.701	1.328
AH-50	50	CA3-8	2 1/4-12	9.75	1.38	6.00	1.38	1/2 SHCS	1.057	2.208	1.768

NOTE: ADAPTER & RING MAKE A SET

NOTE: Damage could occur to machines unless proper alignment is installed between die set and cylinder rod connection.

* Special threads can be machined. Consult Factory For Application.

