

# **BLACK & WEBSTER**

## **AIR PRESS**

### **MODEL AP1900D**

## **INSTALLATION, OPERATING & MAINTENANCE INSTRUCTIONS**



Black & Webster Products Division

**air-hydraulics**  
INCORPORATED

545 Hupp Avenue ▪ Jackson, Michigan 49204

Ph: 517-787-9444 ▪ Fx: 517-787-7585

[www.airhydraulics.com](http://www.airhydraulics.com) ▪ [info@airhydraulics.com](mailto:info@airhydraulics.com)

Serial No. \_\_\_\_\_

Document ID: UM-BWAP-1900-D-20170926

Revision: Original

## TABLE OF CONTENTS

Installation and Setup .....	3
Maintenance .....	3
Disassembly .....	4
Troubleshooting Guide .....	4 & 5
Pneumatic Circuit .....	6
Part List .....	7
Parts Drawing .....	8

### MACHINE GUARDING

Machine guarding is the responsibility of the user. Provisions must be made to protect the operator and other employees from injury as a result of contact with work in progress, moving parts, mechanical motions of the press, etc. Air-Hydraulics cannot provide “standard” guards for its products due to the variety of tooling used by its owners. However, Air-Hydraulics will be happy to install guards and similar safety devices for operator protection. These safety devices must be produced at the request of and with the design approval of the purchaser.

### WARRANTY

We warrant to the original user that all products of our manufacture will be free from defects in material and workmanship and will possess the characteristics represented in writing by us. Claim for breach of the above warranty must be made within a period of one (1) year from the date of delivery to the user. Upon satisfactory proof of claim, we will make any necessary repairs or corrections, or, at our option, replace defective parts at the factory, transportation charges prepaid. Charges for correcting defects will not be allowed, nor can we accept goods returned for credit unless we are notified in writing and the return or correction is authorized by us in writing. The FOREGOING IS IN LIEU OF ALL OTHER WARRANTIES, EXPRESSED OR IMPLIED, INCLUDING ANY WARRANTIES THAT EXTEND BEYOND THE DESCRIPTION OF THE PRODUCT. This paragraph sets forth the extent of our liability for breach of any warranty in connection with the sale or use of our products. It is understood we will not be liable for consequential damage such as loss of profit, delays, or expense whether based on tort or contract.

## INSTALLTION

1. Place press on rigid bench or table at a convenient height for operator. Bolt securely to the bench.
2. Connect 100 P.S.I. filtered shop air supply (40 micron min) to 3/8 N.P.T. inlet port of air prep assembly.

## SET UP AND OPERATION

1. Loosen locknut and adjust pressure regulator until pressure gauge reads desired pressure (100 P.S.I.). **CAUTION:** Do not operate at pressure greater than 125 P.S.I.
2. Adjust speed control valve to slow position by turning valve stem clockwise (or in).
3. Check to make sure safety sleeve assembly is in the correct position on the press before operating
4. Keeping hands clear of shaft, actuate press by depressing palm buttons.
5. Release palm buttons. Shaft should return to fully retracted position (2 pos. circuit) or stop movement (3 pos. circuit)
6. Remove safety sleeve from press.
7. Loosen locking nut and adjust stop nut to obtain desired stroke. Distance between bottom of the stop nut and top surface of stop cap or frame is the stroke of the shaft. **CAUTION:** Do not back off locking nut beyond top of threaded shaft. Doing so may damage packings.
8. Replace safety sleeve and re-actuate press.
9. If necessary, re-adjust stop nut, speed control and pressure regulator to obtain desired setting. **CAUTION:** Never operate press unless safety sleeve is in place and hands are clear of shaft.
10. Install tooling into hole provided in shaft, securing with set screw.
11. Install dies, nests or anvils onto base using tapped holes provided.
12. Make any final stroke, speed and pressure adjustments to obtain desired workpiece configuration with tooling in place.

## MAINTENANCE

### LUBRICATION

Air presses are lubricated at the factory and should require no additional lubrication. However, if a press is disassembled for service or replacement of parts, all internal surfaces should be coated with a light bearing grease such as Lubriko M6 (Master Chemical Co.) or equivalent.

### CUSHION ADJUSTMENT

Model AP 1900D employs an external cushion spring for the return stroke. The cushion is preset at the factory and should require no further attention. However, if the machine should begin to “hammer” during the return stroke, cushion adjustment may be necessary, as follows:

1. Remove safety sleeve from press
2. Loosen cushion adjustment locking nut.

3. Rotate cushion adjustment locking nut upward to increase spring compression, slightly.
4. Re-tighten locking nut.
5. Replace safety sleeve.
6. Adjust return speed control to maximum fast position.
7. Actuate press & check for “hammering” during the return stroke
8. If necessary, repeat cushion adjustment until ram returns gently to its rest position.
9. Re-adjust return speed control to obtain desired return stroke speed.

**GIB ADJUSTMENT**

Model AP 1900D has a square shaft retained by two adjustable gibs. If any side play or rotation is noticed in the shaft of these models, a gib adjustment may be necessary. Adjustments as follows:

1. Along the centerline of the shaft at the front and right side of the press, two (2) set screws will be found for each of the two (2) gibs.
2. Adjust set screws inward on one (1) gib at a time until all side play is removed from shaft. Do not over-tighten gibs or press may jam or operate erratically. Gibs should be just tight enough to remove all side play and rotation from shaft.

**PRESS DISASSEMBLY**

Should press disassembly become necessary in order to service or replace parts, use extreme caution.

Remove air supply. Cylinder should be in retracted position. Ram & shaft may fall, be sure to block up ram in the platen area. Remove hex screws holding cylinder cap in place. Now remove any fastener you need to replace parts. Re-assembly should be approached with the same cautious manner. **Torque cylinder mounting fasteners to 23 ft. lbs. each.**

Air-Hydraulics, Inc. maintains complete facilities at all times for the repair of air presses. If qualified maintenance personnel are not available at a customer’s plant, the press may be returned to the Air-Hydraulics, Inc. for service.

**TROUBLESHOOTING GUIDE**

PROBLEM	CAUSE	REMEDY
A. Shaft fails to extend after hand valve actuated or fails to return to rest position	<ol style="list-style-type: none"> <li>1. Insufficient air pressure</li> <li>2. Speed control valve closed or clogged</li> <li>3. Power valve not shifted</li> </ol>	<ol style="list-style-type: none"> <li>1. Clean supply, adjust or clean regulator</li> <li>2. Open speed control valve or clean blockage</li> <li>3. Check for adequate pilot air from hand valve &amp; for jammed spools</li> </ol>

	<ol style="list-style-type: none"> <li>4. Hand valve clogged</li> <li>5. Shaft bent</li> <li>6. Gibs too tight</li> </ol>	<ol style="list-style-type: none"> <li>4. Clean hand valve</li> <li>5. Replace shaft</li> <li>6. Adjust gibs (see maintenance)</li> </ol>
B. Ram moves erratically	<ol style="list-style-type: none"> <li>1. Gibs too tight</li> <li>2. Insufficient lubrication</li> <li>3. Air Leaking past packings</li> <li>4. One or more valves clogged or leaking</li> </ol>	<ol style="list-style-type: none"> <li>1. Adjust gibs (see maintenance)</li> <li>2. Re-lubricate press</li> <li>3. Replace packing</li> <li>4. Clean or repair valves</li> </ol>
C. Excess rotation of shaft	<ol style="list-style-type: none"> <li>1. Gibs loose or worn</li> </ol>	<ol style="list-style-type: none"> <li>1. Re-adjust gibs (see maintenance)</li> </ol>
D. Reduced force at a given pressure	<ol style="list-style-type: none"> <li>1. Air leaking past packings</li> <li>2. Gibs too tight</li> </ol>	<ol style="list-style-type: none"> <li>1. Replace packings</li> <li>2. Re-adjust gibs (see maintenance)</li> </ol>
E. Shaft "hammering" on return stroke	<ol style="list-style-type: none"> <li>1. Cushion spring loose or broken</li> </ol>	<ol style="list-style-type: none"> <li>1. Replace spring if broken, re-adjust cushion (see maintenance)</li> </ol>

# PNEUMATIC DIAGRAM

## SINGLE ACTING CYLINDER WITH DUAL PALMS & ANTI-TIE DOWN

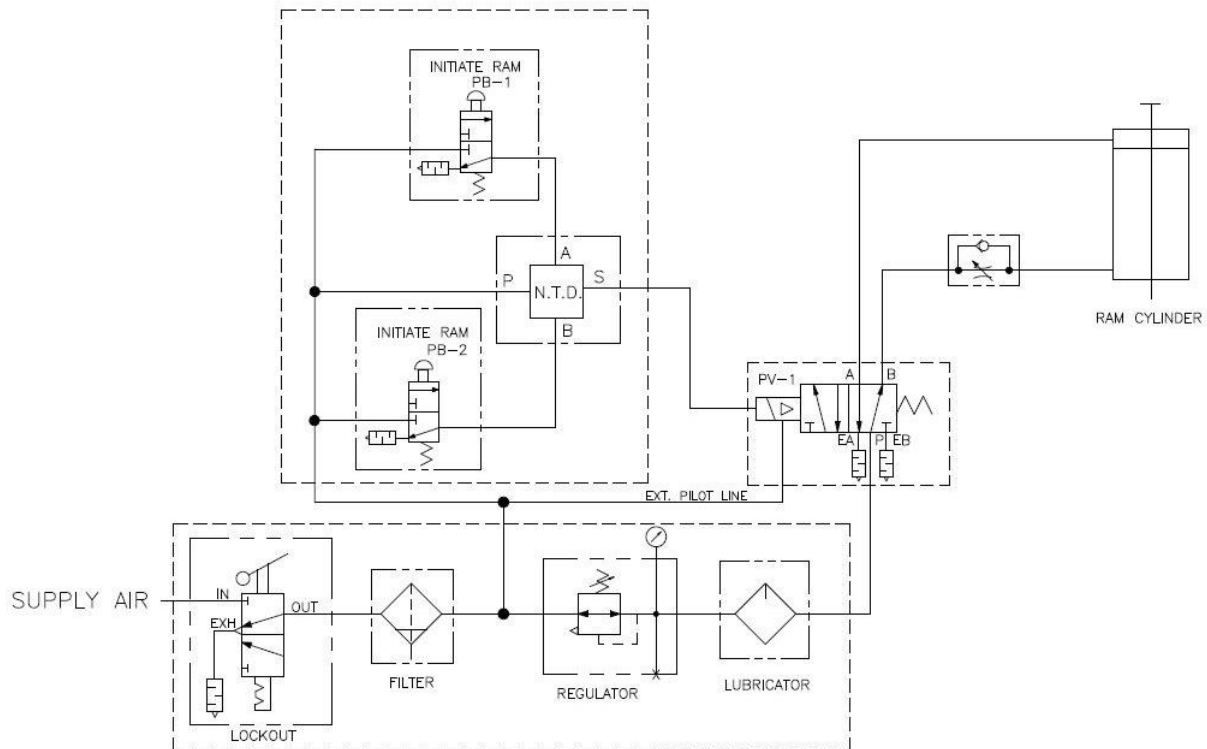

### AP 1900

<b>Length of Stroke</b>	<b>0-2" adjustable</b>
<b>Throat Depth</b>	<b>5.00"</b>
<b>Opening of Ram to Base</b>	<b>6.00"</b>
<b>Tool Hole in Ram</b>	<b>.81 dia. X 1.50 deep</b>
<b>Force at 100 P.S.I.</b>	<b>Up to 1900 lbs.</b>
<b>Ram Style</b>	<b>Square with gib</b>
<b>Net Weight (less controls)</b>	<b>132 lbs.</b>
<b>Controls (optional)</b>	<b>Flow Control Valve Pressure Regulator Pressure Gauge High flow power valve Exhaust Air Muffler 3 position valve (JOG)</b>

**PARTS LIST**  
**AP1900 AIR PRESS**

ITEM	PART #		DESCRIPTION	QTY
1	203035		Base	1
2	203075		Frame	1
3	203037		Cylinder	1
4	203038		Cylinder cap	1
5	203040		Cylinder base	1
6	203041		Ram	1
7	203076		Front cover	1
8	203077		Bronze gib	2
9	203044		Washer	1
10	203046		Cup retaining washer	2
11	203048		Spacer posts	3
12	203049		Retainer washer	1
13	203053		Stop nut	1
14	20305402		Spring cushion nut	1
15	203056		Shaft	1
16 (RK)	203045		Piston packing	2
17 (RK)	203050		Cylinder base packing	1
18 (RK)	203051		O-ring	2
19 (RK)	203052		Cylinder gasket	2
20	203055		Cushion spring	1
21	203108		Safety sleeve	1
22	203047		Spring return	1
23	203066	*	Repair kit	1

\* Not shown on drawing

(RK) Items in repair kit #203066

# AP1900 PARTS DRAWING

