

Index Table Counter Clockwise

Model 794-CC

Installation, Operating and Maintenance Instructions

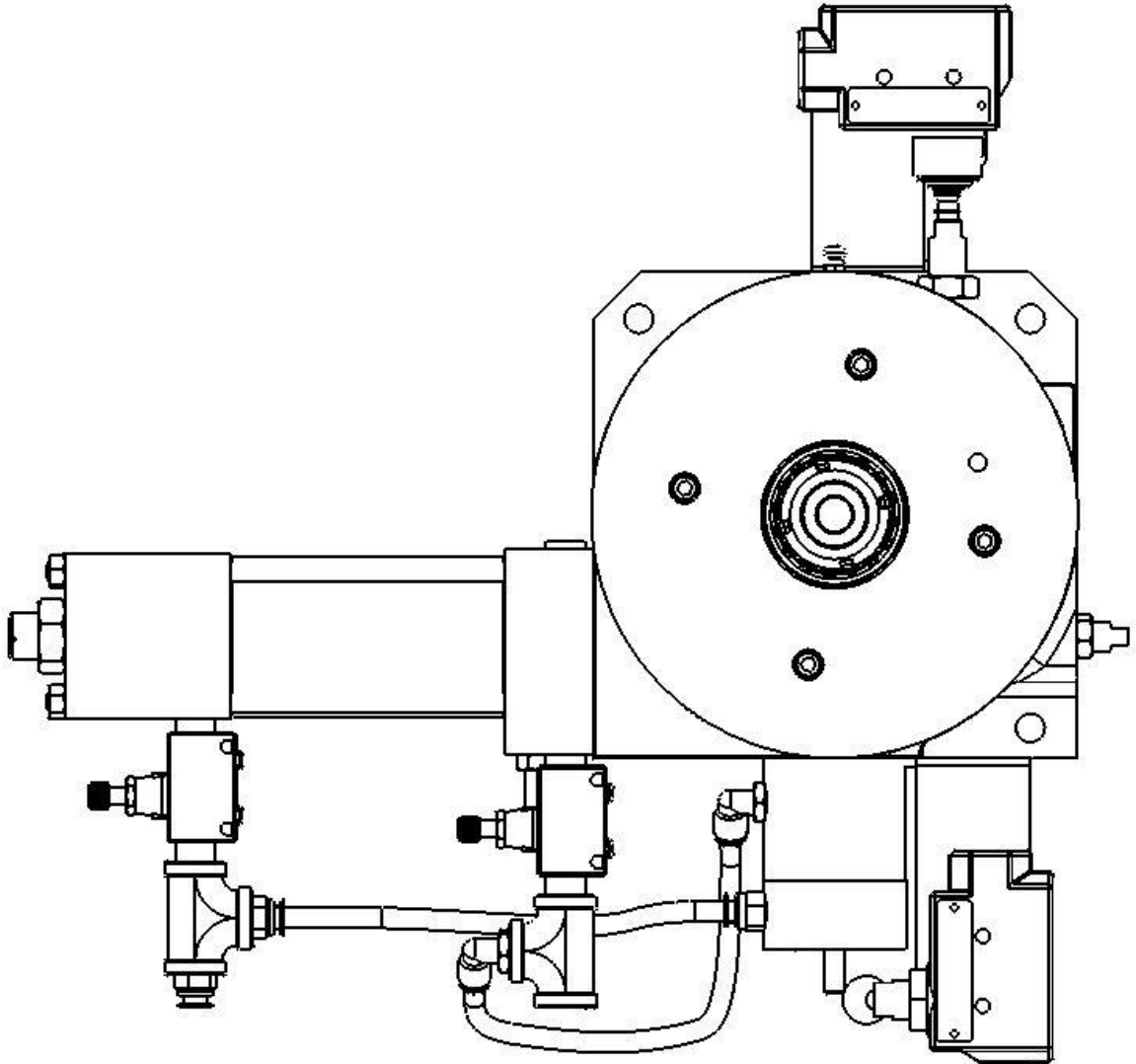

Black & Webster
Assembly Equipment Division

air-hydraulics
INCORPORATED

Black & Webster Products Division

545 Hupp Ave. P.O. Box 831, Jackson, Michigan 49204

Phone: (517- 787-9444 Fax: (517) 787-7585

Email: info@airhydraulics.com

2009

Serial No. _____



Black & Webster Products Division
 545 Hupp Ave. P.O. Box 831, Jackson, MI 49203
 Phone: (517- 787-9444 Fax: (517) 787-7585
 Email: info@airhydraulics.com

Table of Contents

Table Hook-Up.....3

Sequence of Operation.....3

Table Adjustments.....4

Maintenance.....5

Tool Mounting Instructions.....5

Piping Schematic.....6

Parts List.....7

Parts Drawings.....8

Table Dimensions.....9 & 10

Table Motion Layout.....11

Warranty

Air-Hydraulics, Inc. warrants to the original user that all products manufactured will be free from defects in material and workmanship and will possess the characteristics represented in writing by us. Claim for breach of the above warranty must be made within a period of one year from date of delivery to the user. Upon satisfactory proof of claim, we will make any necessary repairs or corrections, or at our discretion, replace defective parts at the factory, transportation charges prepaid. Charges for correcting defects will not be allowed, nor can we accept goods returned for correction unless we are notified in writing and the return or correction is authorized by us in writing. **The foregoing is in lieu of all other warranties, expressed or implied, including any warranties that extend beyond the description of the product.** This paragraph set forth the extent of our liability for breach of any warranty in connection with the sale or use of our products. It is understood we will not be liable for consequential damages such as loss of profit, or expense, whether based on tort or contract. This warranty is void if the articles covered by the warranty have not been properly installed, maintained and used.

Table Hook-Up

Air-Hydraulics Inc. recommends that the air line supplying the table be at least ¼" pipe or ¼" i.d. hose. The maximum pressure is 110 p.s.i. Anything above this could be dangerous to the machine operator or other personnel.

Refer to schematic (pg. 5) when plumbing controls for the table hook-up. On ¼" n.p.t. 2-position, 4-way valve controls the index cylinder and locking cylinder. Care should be taken not to restrict flow to the table.

When checking the table for operation after hook-up, make sure the table is held securely (clamped or bolted). The table can shift or jump if left loose on a bench.

Sequence of Operation

The sequence of operation of the indexer is as follows:

1. The directional control valve is shifted by the pilot or solenoid signal. This causes the locking cylinder to retract, unlocking the table. **Note:** The signal to the solenoid or pilot must be maintained until the table top has completed its movement.
2. With the locking cylinder of the index ring, the index cylinder retracts, moving the index arm which in turn turns the table top.
3. After the index cylinder is fully retracted, the directional control valve is shifted back. This forces the locking cylinder forward and locks the table into position. When the locking cylinder locks the table into place, it pushes the index pawl out of the index ring.
4. With the index pawl clear of the index ring, the index cylinder moves forward until it hits the stop rod. When the stop rod is adjusted properly, the index pawl is spring activated into the next slot on the index ring and the index cycle is complete.
5. The index table is now ready for the next index cycle.

Note: If using a manual operation to shift the directional control valve that controls the index cylinder, make sure to hold the valve fully shifted until the table stops moving. There is a built-in cushion for the index cylinder which slows the movement of the table just before the cylinder is fully retracted. If the valve is released too soon, the locking cylinder may not be able to engage the locking ring. If the table is not locked, the table top will return to its original position.

Table Adjustments

Air-hydraulics Inc. index tables are built, tested, and adjusted at the factory prior to shipment. After receipt of the table, you may find minor adjustments are required to meet your operational requirements.

The first adjustment should be in the general speed of the table during the index. The speed control on the index cylinder is turned clockwise to decrease the indexing speed of the table. Turning the speed control counter-clockwise will increase the speed of the rotation. Care must be taken not to set the speed of the table so high that the cushion will not be able to slow the cylinder.

The second adjustment is the cushion. Turning the cushion adjustment screw in the clockwise direction increases the amount of cushioning. Turning counter-clockwise decreases the amount of cushioning. The cushion should be set so a visible slowing of the table top occurs just prior to stopping. ***Do not operate the index table if the cushion is not functioning.*** The index table can be damaged if there is insufficient cushioning of the table top.

The third adjustment is the override stop. This stop aligns the notch in the index ring with the locking cylinder plunger. If movement in the table is detected when the locking cylinder plunger engages into the index ring, loosen the large jam nut on the override stop-bolt. Make minor changes clockwise or counter-clockwise until the movement is eliminated. Then, re-tighten the jam nut.

Adjustment of the stop-rod should not be necessary as it has been adjusted at the factory. In the event of the table being disassembled for repair or maintenance, it may become necessary to adjust the stop-rod. The stop-rod is used to adjust the point where the index pawl drops into a slot in the index ring and is ready to index the table top. If the stop-rod is inadvertently moved, use the following procedure to readjust the stop-rod. Remove connections for the power source from the index table; loosen the jam nut on the stop-rod until there is approximately 1-1/2" of threads showing. Make sure the table is in position to be locked and then apply power to the back of the locking cylinder. With the signal maintained to the locking cylinder, pressurize the back of the index cylinder and slowly turn the stop-rod in a clockwise direction until the pawl drops into a slot in the ring. If the table is locked up, the stop-rod will not be able to be turned when the pawl drops in the slot. Turn the stop-rod in a counter-clockwise direction ¼ to ½ turns and tighten the jam nut. The index cylinder stroke should be correct, allowing the pawl to drop into a slot every cycle.

Maintenance of Index Table

In order to extend the life of the table and achieve maximum efficiency, it is recommended that all seals and gaskets be changed on a yearly basis. When changing seals and gaskets, we also recommend that the index pawl return spring be changed at the same time. After repeated index cycles, the effectiveness of the pawl return spring is lessened.

A regular lubrication schedule is recommended to maintain accuracy and reliability in the index table. Grease fittings are supplied and should be greased (1-2 pumps of a good quality lithium grease) on a weekly basis to start. Take care not to over lubricate the table. Excess grease will accumulate inside of the table and will cause internal parts of the table to move slower due to increased friction.

It is recommended that at least one complete seal kit be stocked to repair your table. Seals and gaskets are sold in complete sets only.

If any problems are encountered with your table, feel free to call Air-Hydraulics, Inc., Jackson, Michigan, and someone in our service department will be glad to assist. If a comprehensive maintenance program suited for your application is desired, we can also help set up a program.

Instructions for Mounting Tooling to Air-Hydraulics Inc. Indexer

1. Mount table to the machine where the drilling, tapping, reaming, etc. is to be done. If the sub-plate has already been installed by the factory, remove it from the index table.
2. Connect the power source to the table with the proper valving according to the schematic and instructions provided.
3. Index the table to insure proper operation. The table must be in the locked position before machining.
4. Indicate sub-plate mounting holes from the center hole through the table spindle (.500" dia.) or the center hole in the table top (2.12:" dia.). Locate the bolt and dowel pin holes from the drawing provided by Air-Hydraulics, Inc.

Caution: Holes in the table top must not break through to the table base. A maximum depth of 7/16" is recommended. Use a bottom tap for the 1/4"-20 UNC. tapped holes.

5. The sub-plate should have a .500" diameter bored hole in the center of its bottom surface. This hole coincides with the center hole of the table spindle. With this hole as an indicating center, the mounting holes in the sub-plate can be drilled to match those in the table top.
6. Install the sub-plate on the table.
7. Perform the work required to install tooling, tooling nests, clamps, etc. on the sub-plate at the position required.
8. Index the table and repeat step (7) until all tooling holes are installed.
9. After all holes are drilled, tapped, reamed, etc. install the tooling next.
10. Remove the table from the drilling machine and position the table on the machine where it is to be used. With the table in the locked position, locate it in the desired location for machine operation. Attach the table to the bolster plate of the machine.

Note: Air-Hydraulics, Inc. recommends that the table and fixtures be doweled in place to insure repeatability.

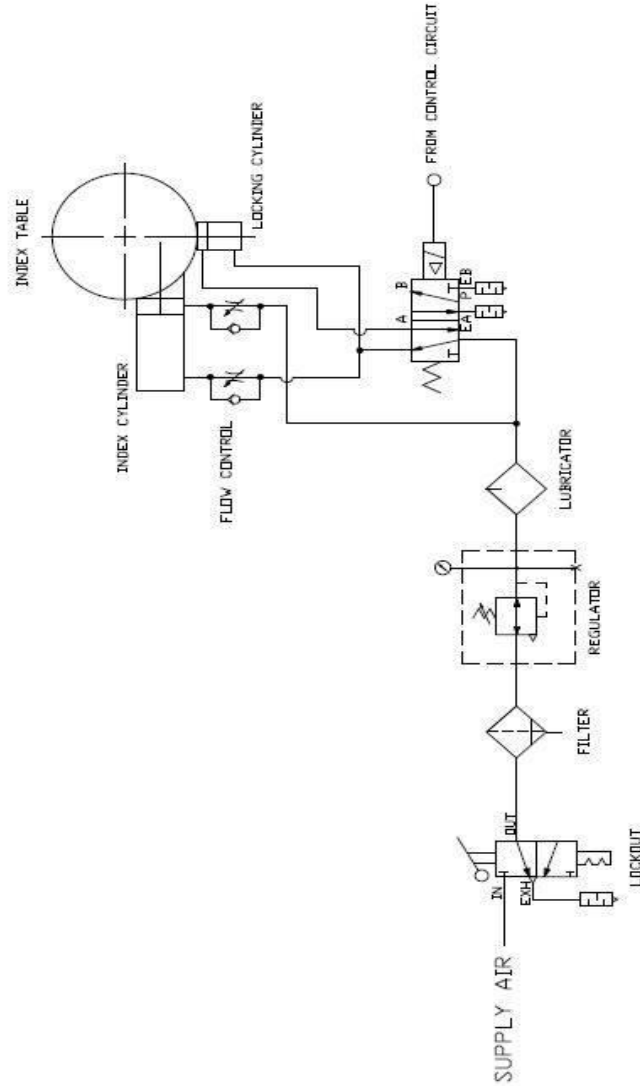

<p>air-hydraulics 545 HUPP AVENUE JACKSON, MICHIGAN 49204-0831 PHONE: (517) 787-9444 FAX: (517) 787-7585 E-MAIL: info@airhydraulics.com</p>	
DESC.	PNEUMATIC POWER SYSTEM
MODEL	INDEX TABLE-CC
SCALE	1/2"
DRG. NO.	IT-PS070-CC
REV. NO.	1
DATE	11/10/20
BY	DATE
CHK. BY	DATE
LET.	DESCRIPTION
	IT-PS070

UNLESS OTHERWISE SPECIFIED:
 TOLERANCES - X = ± .030
 .XX = ± .010
 .XXX = ± .005
 .XXXX = BASIC
 ANGLES = ± 1°
 ALL INSIDE CORNERS = .031R.
 BREAK ALL SHARP CORNERS
 .015R. OR .015 x 45°
 REMOVE ALL BURRS
 REPORT ANY ERRORS
 UNITS = U.S. INCHES

NOTICE
 The information disclosed on this document is proprietary and shall not be disclosed, used or duplicated for procurement or manufacturing purposes without the expressed written consent of Air-Hydraulics, Inc.

Model 794 Index Table Parts List

Detail No.	Part No.	Part Name (CC= Counter clock)	Qty.
1	T794-CC-01	Base, CC	1
2	T700-02	Table Top	1
♦3	T700-03-“##”STA	Station Ring	1
4	23204	Station Ring Mounting Screw	4
5	26751	Sta. Ring Location Pin	1
6	T700-CC-06-ASSY	Index Arm, CC	1
7	T700-07	Index Pawl	1
8	T700-08	Pawl Return Spring	1
9	T700-09	Spindle	1
10	TCN-07097 TCN-07204	Main Bearing Cone Main Bearing Cup	1
11	T700-11	Main Bearing Lock Nut	1
12	T700-12	Spindle Ret. Nut	1
13	T700-CC-13	Index Cyl. Front Cap, CC	1
14	T700-CC-14	Index Cyl. Body, CC	1
15	T700-CC-15	Index Cyl. Back Cap, CC	1
*16	See notation below	Index Cyl. Gasket	2
17	T700-CC-17 82476	Index Cyl. Tie Rod, CC Index Cyl. Nut	4
18	T700-18	Index Cyl. Piston	1
*19	See notation below	Index Cyl. Piston O-ring	1
20	T700-20	Cushion Rod	1
*21	See notation below	Cushion Rod O-ring	1
23	T700-23	Index Cyl. Rod	1
*24	See notation below	Index Cyl. Rod Seal	1
25	T700-CC-25	Index Piston Rod Assy.	1
26	T700-26	Connecting Link	1
27	T700-27	Locking Cyl. Body Assy	1
28	T700-28	Locking Cyl. Back Cap	1
*29	See notation below	Locking Cyl. Gasket	1
30	23215	Locking Cyl. Mtg. Scr.	3
31	26751	Connecting Link Pin	1
32			1
33	T700-33	Locking Cyl. Piston	1
*34	See notation below	Locking Piston O-ring	1
*35	See notation below	Locking Piston Rod Seal	1
*36	See notation below	Actuating Rod Seal	1
37	T700-CC-37	Cushion Adj. Valve	1
*38	See notation below	Cushion Adj. Valve Seal	1
39	24133	Check Valve Plug	1
40	111	Check Valve Spring	1
41	BALL-0.375	Check Valve Ball	1
42			
♦43	T700-CC-43-“##”	Stop Rod	1
44	35205	Stop Rod Lock Nut	1

Detail No.	Part No.	Part Name (CC= Counter clock)	Qty.
45	36256	Cushion Adj. Valve Nut	1
46	RQ8	Limit Switch No. 1	1
47	T700-47	Limit Switch Brkt.	1
48	2RN	Limit Switch No. 2	1
49	T700-CC-49	Limit Switch Brkt CC	
50	T150-59	Actuator Rod Spring (#1)	1
51	T700-CC-51	Actuator Rod, CC	1
52	68007	Snap Ring for Item #51	2
54	T794-54	Straight Grease Zerk	1
55	FRL-1014104-F02	Speed Control Valve	1
56	36265	Over Ride Stop-bolt Nut	1
57	T794-57	Over Ride Stop-bolt	1
58	23163 33074	Limit Switch Brkt. Scr. Limit Switch Brkt. Washer	2
59	68007	Snap Ring for Item #51	2
60	T700-CC-60	Switch rod CC	1

* All O-rings and gaskets and seals are sold collectively as a kit. The part number is: 794-CS.

- All O-rings and gaskets and seals are not called out on parts drawing

♦ “##” equals the number of stations or index positions. For example, if four stations, or 90 degree index, then the part number would be T700-03-04STA.

•For three station use, the part number would be T700-S3-43-3A0140. For four stations and up, “##” equals the number of stations or index positions. For example, if four stations, or 90 degree index, then the part number would be T700-43-04STA; five stations would be T700-43-05STA.

Note: When ordering replacement parts for this table, specify model 794 and the serial number. Air-Hydraulics cannot be held responsible for parts shipped in error if the model and serial number are not supplied.

Cylinder Torque Specifications		
Model	Mounting Bolt (ea)	Tie Rod (ea)
794-xx	61 in. lb.	76 in. lb.

Drawing on Page 8 

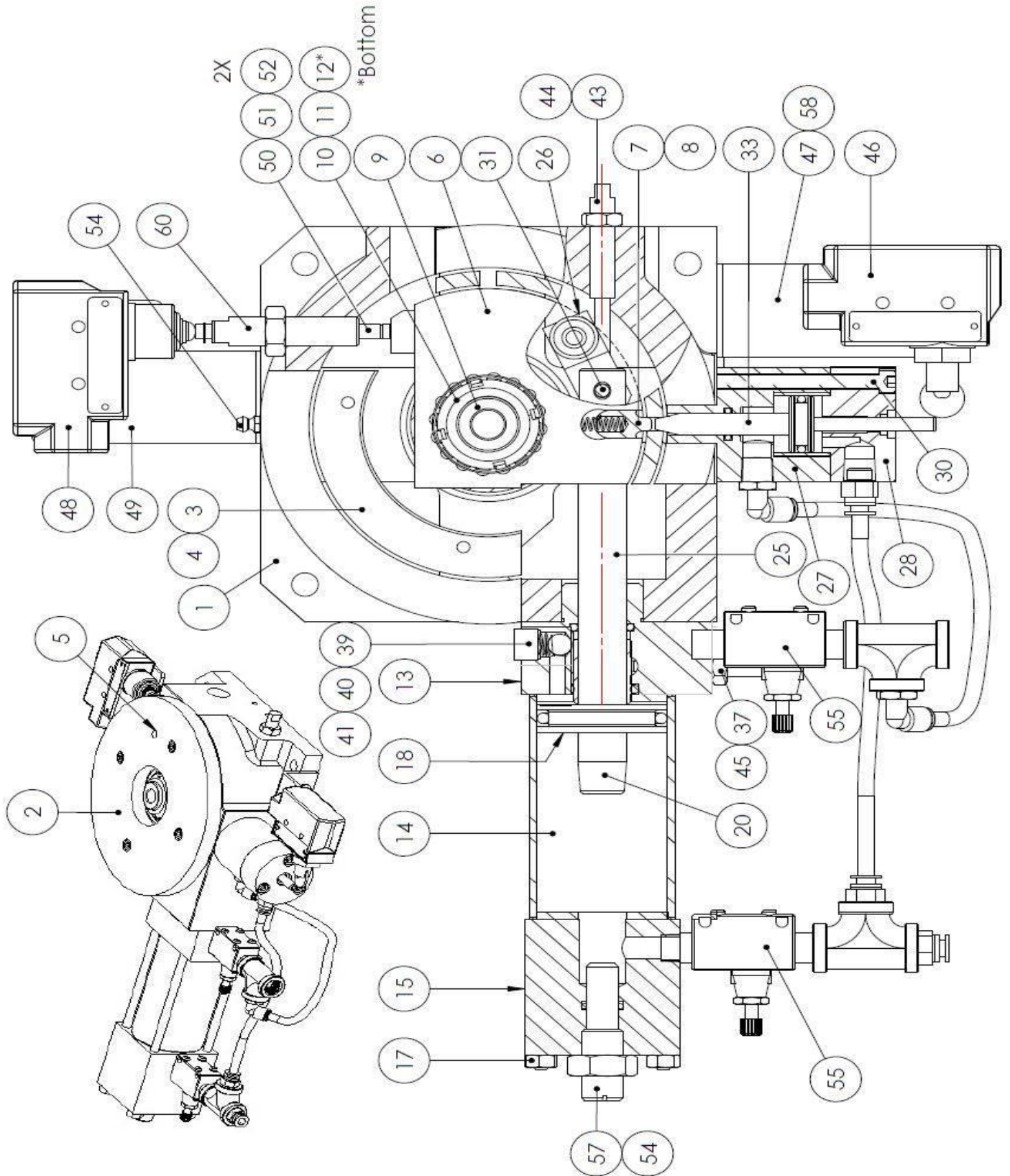

Model 794 Dimensions

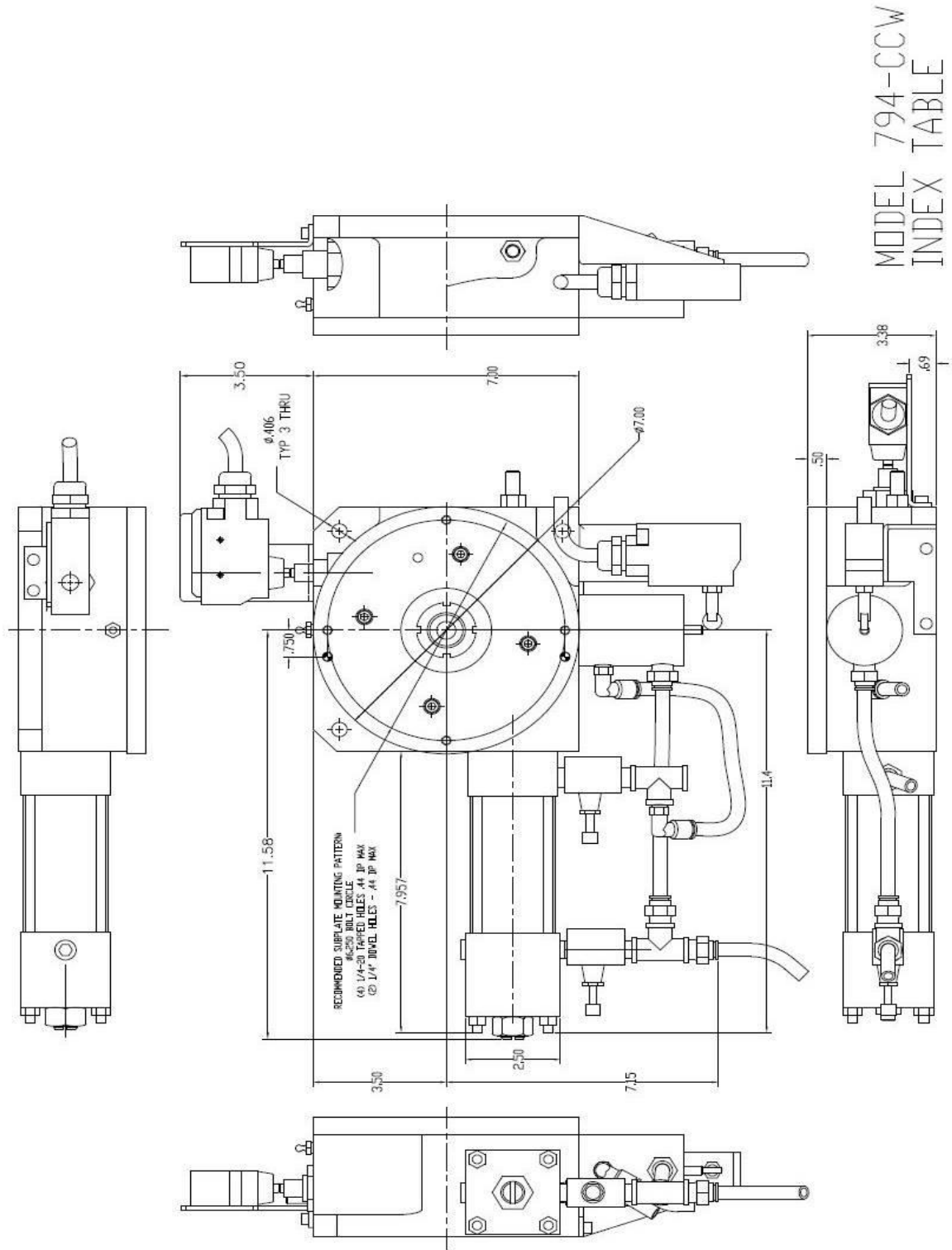

MODEL 794-CCW
 INDEX TABLE

Model 794 Dimensions Continued

Dial Plate Diameter	7"
Dial Plate Material	Fremax 15
Recommended Max. Tooling Wt. within Table O.D.	
Without LFLS Wear Bearing	100 lbs.
With LFLS Wear Bearing	200 lbs.
Max. Unsupported Sub-Plate O.D.	14"
Standard Index Range	4 to 24
Spindle Through Hole I.D.	½"
Accuracy (at table diameter)	±.001"
Cushioned Index Stroke and Speed Control	Standard
Torque or Power Stroke	200 lbs., 2' radius
Max. Cylinder Stroke	2.950"
Max. Side Pressure (Radial lbs. @ 500 r.p.m.)	795 lbs.
Thrust (@ 500 r.p.m.)	630 lbs.
Max. Side Pressure in Stop Position	3,150 lbs.
Air Requirements	
Air supply must be filtered and lubricated	
Supply Pipe size (min.)	¼" NPT
Min. Air Pressure	80 PSIG
Max. Air Pressure	110 PSIG
Air Consumption @ 100 PSIG	20 in ³ /cycle
Valve required	2 pos 4 way
Shipping Weight	56

**EIGHT STATION INDEX TABLE PNEUMATIC
POWERED CLOCKWISE ROTATION**

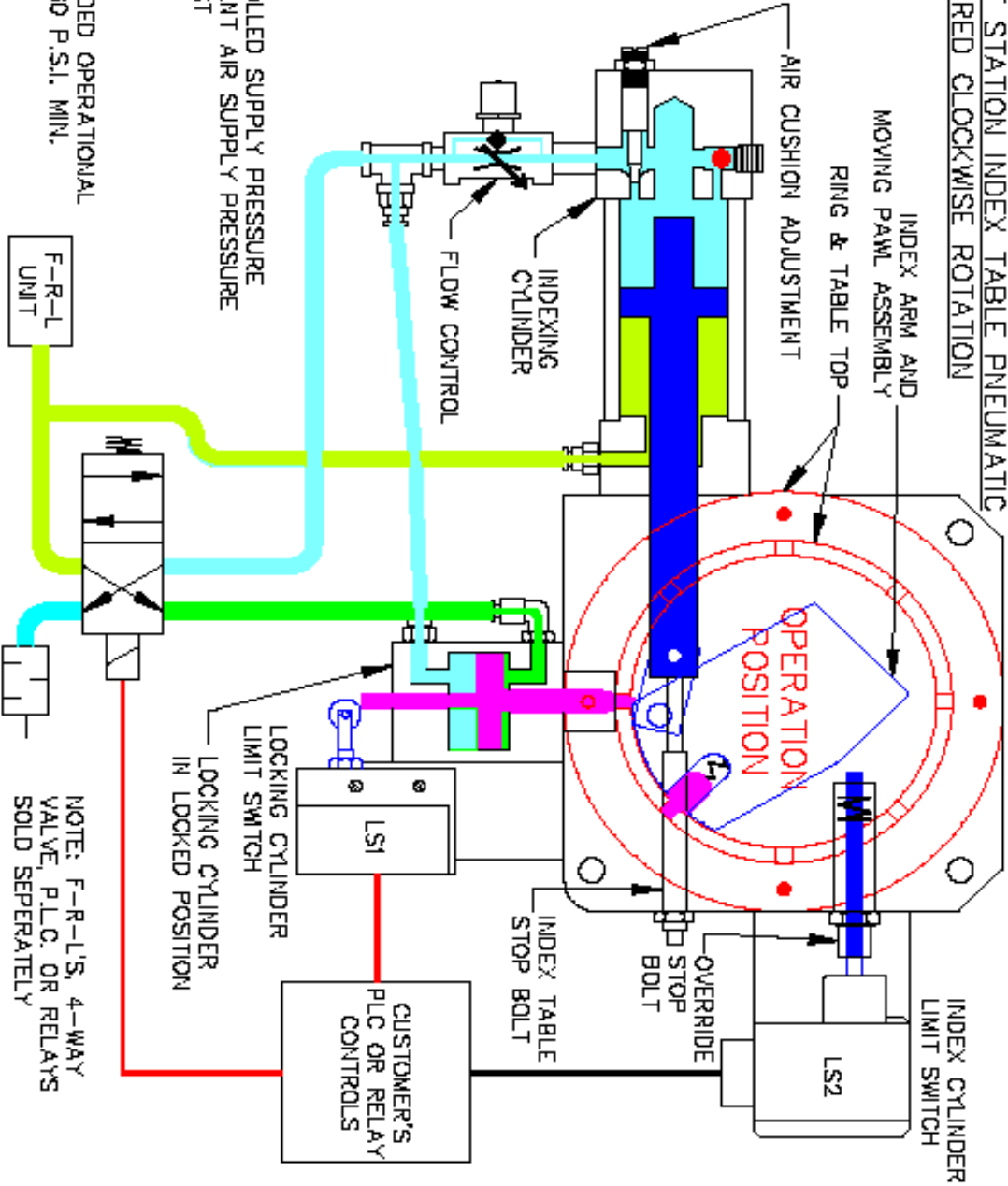

- LEGEND:**
- █ = CONTROLLED SUPPLY PRESSURE
 - █ = CONSTANT AIR SUPPLY PRESSURE
 - █ = EXHAUST

**NOTE: RECOMMENDED OPERATIONAL
PRESSURE 80 P.S.I. MIN.**

F-R-L
UNIT

**NOTE: F-R-L'S, 4-WAY
VALVE, P.L.C. OR RELAYS
SOLD SEPERATELY**

**NOTE: THE FULL INDEX TABLE MOTION CAN BE FOUND AT:
<http://www.dirthydraulics.com/Products/IndexTables/animation.htm>**

**TABLE SHOWN LOCKED FOR
MACHINING OPERATIONS**